

ACDEU

Solids Handling Vortex Hydraulic Motor Driven



Submersible Pump

Models HSV3A1-HYD and HSV3B31-HYD

Size 3"

PUMP SPECIFICATIONS

Casing: HSV3A1-HYD Aluminum 356-T6 .
Maximum Operating Pressure 37 psi (255 kPa).*
HSV3B31-HYD Ductile Iron 65-45-12.
Maximum Operating Pressure 46 psi (317 kPa).*

Impeller: Six Vane Vortex, CA6NM Stainless Steel.
Handles 2 1/2" (64 mm) Diameter Spherical Solids.

Wear Ring: Ductile Iron 65-45-12.

Hydraulic Motor Housing: Die Cast Aluminum.

Shaft: 4140 Alloy Steel.

Motor Housing Bearings: Needle Type.
Bearing Lubrication: SAE 30 Non-Detergent Oil.

O-Rings: Buna-N.

Hardware: Stainless Steel.

Standard Equipment: Trash Strainer. Hoisting Handle.
1/2" (12,7 mm) Hydraulic Tool Manufacturer's Association (H.T.M.A.) Quick Disconnect Fittings for Hydraulic Motor Inlet and Return.

Optional Equipment: Water Strainer with 3/8" (9,6mm) opening.
1/2" (12,7 mm) Hydraulic Hoses with H.T.M.A. Quick Disconnect Fittings for Hydraulic Motor Inlet and Return.
Maximum Temperature of Liquid Pumped, 140°F (60°C).*

* Consult Factory for Applications Exceeding Maximum Pressure and/or Temperature Indicated.

** Hydraulic Hose Available in 50 Foot (15,2 Meter) Increments: Maximum Recommended Length 150 Feet (45,7 Meters), Specify Length at Time of Order.

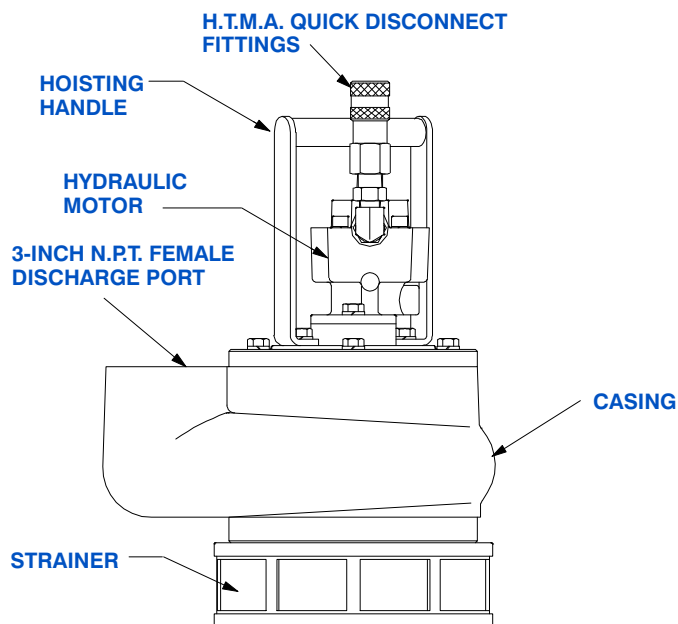

HYDRAULIC MOTOR SPECIFICATIONS

Hydraulic Motor: Fixed Displacement Gear.
Hose Ports: 1/2" (12,7 mm) NPT.
Operating Pressure: Max. 2500 psi (17237 kPa).
Hydraulic Oil: 214-320 ssu @ 100°F (64°C).
Input Flow: Variable, 4-8 GPM (900-1800 LPH).
Power Source: Open Center Hydraulic System.
Recommended Hydraulic Unit: Gorman-Rupp Models HSP-GX390 or HSP-L100AE.

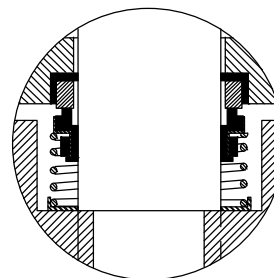

SEAL DETAIL

Mechanical, Oil Lubricated. Carbon Rotating Face, Ceramic Stationary Face. Buna-N Elastomers. Stainless Steel Cage and Spring.



THE GORMAN-RUPP COMPANY • MANSFIELD, OHIO

GORMAN-RUPP OF CANADA LIMITED • ST. THOMAS, ONTARIO, CANADA

www.grpumps.com

Specifications Subject to Change Without Notice

Printed in U.S.A.

Specification Data

APPROXIMATE
DIMENSIONS and WEIGHTS

	HSV3A1-HYD	HSV3B31-HYD
PUMP NET WEIGHT:	28 LBS. (13 KGS.)	59 LBS. (27 KGS.)
SHIPPING NET WEIGHT:	32 LBS. (15 KGS.)	64 LBS. (29 KGS.)
EXPORT CRATE SIZE:	2.2 CU. FT. (0,06 CU. M.)	

SECTION 140, PAGE 600

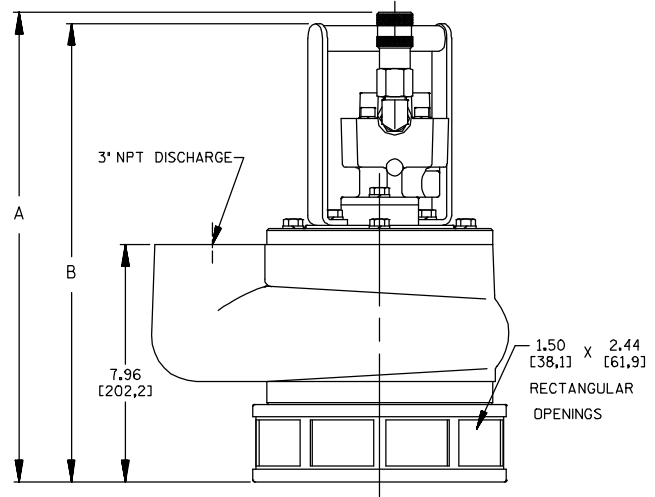
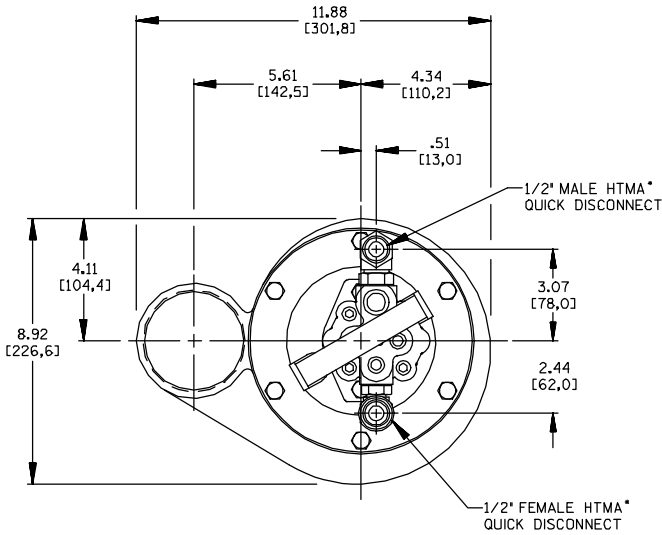

DIMENSIONS:
INCHES
[MILLIMETERS]

• HYDRAULIC TOOL MANUFACTURER'S ASSOCIATION.

MODEL	A	B
HSV3A1-HYD	14.75 [374,7]	14.38 [375,3]
HSV3B31-HYD	15.75 [400,1]	15.38 [390,7]

HSV3B31-HYD SHOWN

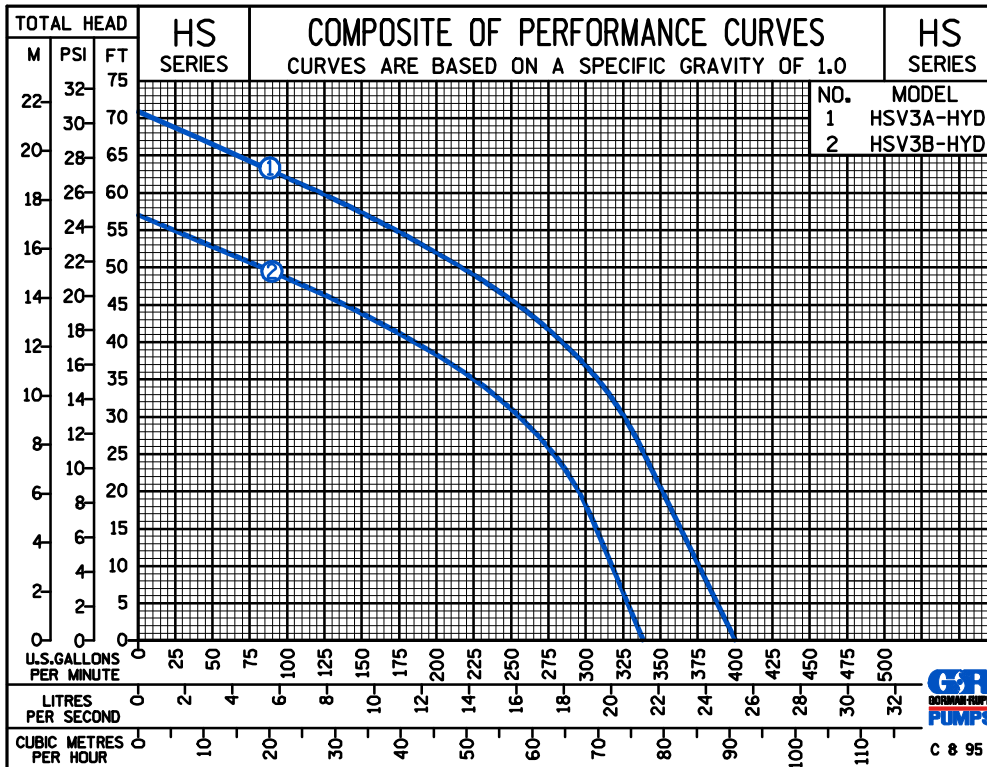

THE GORMAN-RUPP COMPANY • MANSFIELD, OHIO

GORMAN-RUPP OF CANADA LIMITED • ST. THOMAS, ONTARIO, CANADA

Specifications Subject to Change Without Notice

Printed in U.S.A.