

ACDEU



Priming Assisted Centrifugal Pump w/Autostart Model PA6C60-4045T Size 6" x 6"



Total Head		Capacity of Pump in U.S. Gallons per Minute (GPM) at Continuous Performance				
P.S.I.	Feet					
63.3	146	200	200	200	200	200
60.7	140	400	400	400	400	400
52.0	120	820	1000	1000	1000	1000
43.4	100	960	1380	1420	1420	1420
34.7	80	1040	1500	1770	1770	1760
26.0	60	1100	1510	1815	2050	2040
17.4	40	1140	1505	1820	2120	2240
8.7	20	1200	1550	1820	2150	2360
Suction Lift		25'	20'	15'	10'	5'

PUMP SPECIFICATIONS

Size: 6 x 6" (152 mm x 152 mm) Flanged.

Casing: Ductile Iron 65-45-12.

Maximum Operating Pressure 99 psi (683 kPa).*

Open Type, Two Vane Impeller: Ductile Iron 65-45-12.

Handles 3" (76,2 mm) Diameter Spherical Solids.

Impeller Shaft: Stainless Steel 17-4 PH.

Replaceable Wear Plate: Ductile Iron 80-60-03.

Removable Cleanout Cover Plate: Gray Iron 30.

Intermediate Bracket: Gray Iron 30.

Seal Plate: Gray Iron 30.

Seal: Mechanical, Oil-Lubricated. Silicon Carbide Rotating and Stationary Faces. Stainless Steel 316 Stationary Seat. Fluorocarbon Elastomers (DuPont Viton® or Equivalent). Stainless Steel 18-8 Cage and Spring. Maximum Temperature of Liquid Pumped, 160°F (71°C).*

Shaft Sleeve: Stainless Steel 17-4 PH.

Priming Chamber: Gray Iron 30 Housing w/Stainless Steel Float and Linkage.

Discharge Check Valve: Gray Iron 30 Housing w/Buna-N Flapper.

Radial/Thrust Bearings: Open Double Ball.

Bearing Lubrication: SAE 30 Non-Detergent Oil.

Gaskets: Resistant Synthetic Rubber, Cork, PTFE, Vegetable Fiber, and Compressed Synthetic Fibers.

O-Rings: Buna-N.

Hardware: Standard Plated Steel.

Bearing and Seal Cavity Oil Level Sight Gauges.

*Consult Factory for Applications Exceeding Maximum Pressure and/or Temperature Indicated.

Standard Equipment: Gear-Driven Air Compressor. Hoisting Bail. Strainer. Combination Skid Base w/Fuel Tank. Single Ball Type Float Switch**.

Optional Equipment: Battery. Heated Priming Chamber Kit. NPT Suction and Discharge Flange Kits. High Speed (55 MPH/89 KM/H) Single Axle Pneumatic-Tired Wheel Kit w/w/o DOT-Approved Lights and Electric Brakes. Over-the-Road Trailer (Meets DOT Requirements) Available w/Either Electric or Hydraulic Surge Brakes, Running Lights, Jack Stands and Safety Cables. EPS w/Submersible Transducer Liquid Level Sensor (50 Ft. [15M] Cable Standard, Alternate Lengths Available).

**50 Ft. (15 m) Standard Length; Dual Switches and Alternate Cable Lengths Available From the Factory.



WARNING!

Do not use in explosive atmosphere or for pumping volatile flammable liquids.

ENGINE SPECIFICATIONS

Model: John Deere 4045T.

Type: Four Cylinder, Four Cycle, Turbocharged, Liquid Cooled Diesel Engine.

Displacement: 276 Cu. In. (4,5 liters).

Governor: Mechanical.

Lubrication: Forced Circulation.

Air Cleaner: Dry Type.

Oil Reservoir: 17.5 U.S. Qts. (16,6 liters) Dry; 15.5 U.S. Qts. (14,7 liters) Refill.

Fuel Tank: 88 U.S. Gals. (330 liters).

Full Load Operating Time: 19.6 Hrs.

Starter: 12V Electric.

Standard Features: Low Oil Pressure and High Coolant Temperature Safety Shut Down Switches/Indicators. Autostart Instrument Panel Includes: Tachometer, Voltmeter, Hourmeter, Coolant Temperature Gauge, Oil Pressure Gauge, Manual/Stop/Auto Key Switch, 10 Amp Pushbutton Circuit Breaker, Audible Startup Warning Delay, Muffler w/Guard and Weather Cap. Throttle Control.

JOHN DEERE PUBLISHED PERFORMANCE:

Maximum Gross Continuous BHP
(Industrial Heavy Duty) 85 (63 kW) @ 2400 RPM



THE GORMAN-RUPP COMPANY • MANSFIELD, OHIO

GORMAN-RUPP OF CANADA LIMITED • ST. THOMAS, ONTARIO, CANADA

www.grpumps.com

Specifications Subject to Change Without Notice

Printed in U.S.A.

Specification Data

APPROXIMATE
DIMENSIONS and WEIGHTS

	SKID BASE	2-WHEEL
NET WEIGHT:	3520 LBS. (1597 KG.)	4025 LBS. (1826 KG.)
SHIPPING WEIGHT:	3770 LBS. (1710 KG.)	4025 LBS. (1826 KG.)
EXPORT CRATE SIZE:	290 CU. FT. (8,2 CU. M.)	

SECTION 42, PAGE 1130

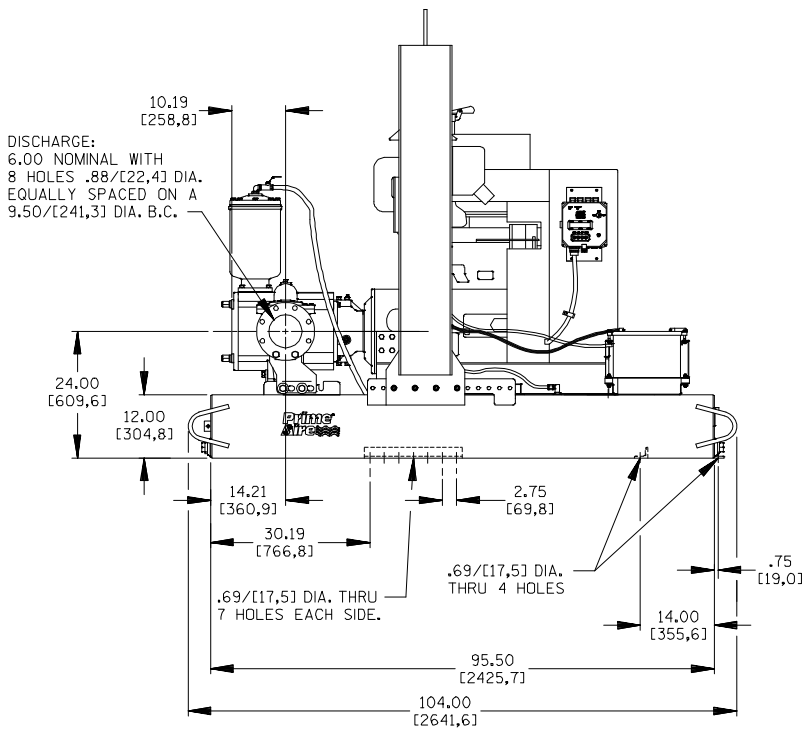
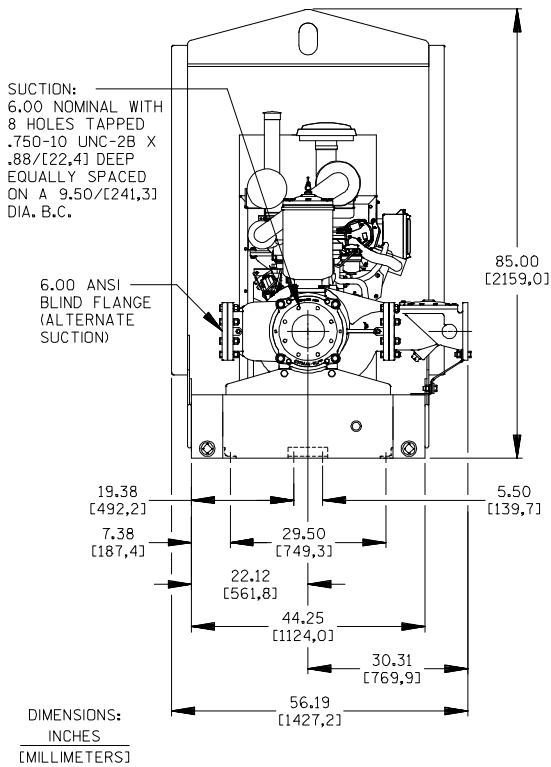

POWERED BY: JOHN DEERE 4045T DIESEL ENGINE
WITH AUXILIARY DRIVE AIR COMPRESSOR.

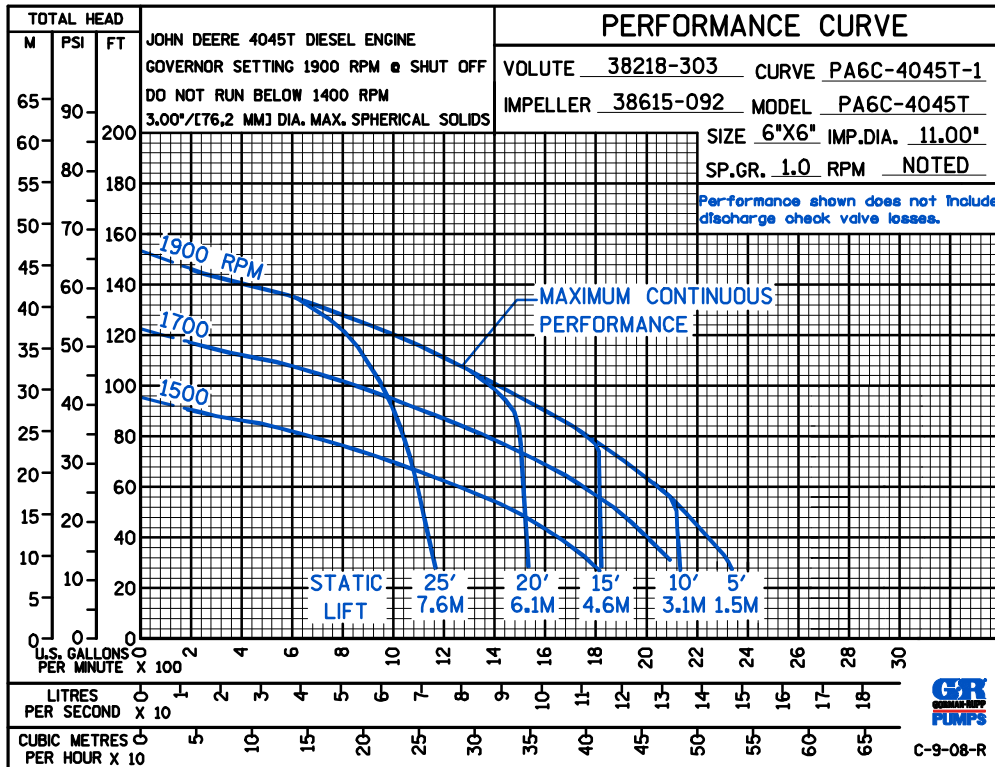

THE GORMAN-RUPP COMPANY • MANSFIELD, OHIO

GORMAN-RUPP OF CANADA LIMITED • ST. THOMAS, ONTARIO, CANADA

Specifications Subject to Change Without Notice

Printed in U.S.A.