

Fuel Cell / Nurse Tank

## Specifications

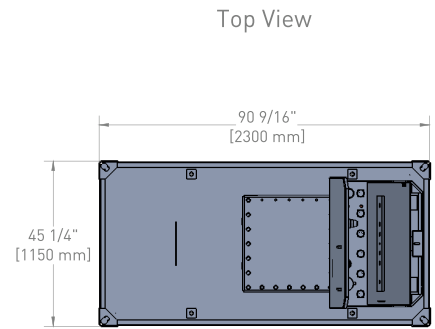
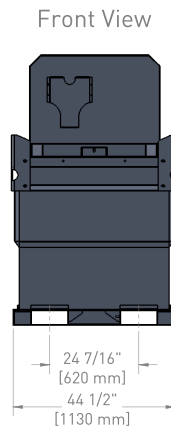
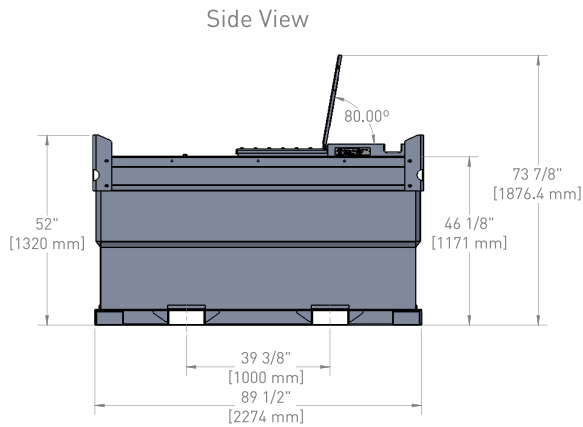

## Certifications & Approvals

- UL 142
- SUN IBC Type 31A
- NFPA
- CAN/ULC-S601
- UN DOT
- Transport Canada

